

MODEL DESIGNATION

◆ Motor model

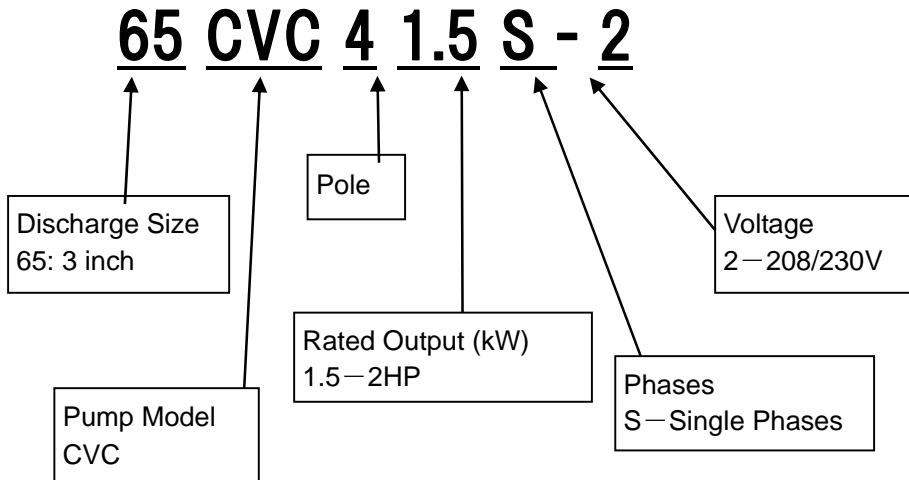

SPECIFICATIONS

Model : 65CVC41.5S-2

	STANDARD	OPTIONAL
Discharge Size	3 inch	
Solid Size	2 inch	
Range of HP	2HP	
Range of Performance	Capacity up to 260(Usgpm) Total Head 6 to 37(ft)	
Limitation		
Type of Liquid Handled	Sewage, Waste water	
Minimum Water Temperature	32° F (0°C)	
Maximum Water Temperature	104° F (40°C)	
Motor	Insulation Class E, Single Phase	
Voltage / Hz	230V, 60Hz	
Synchronous Speed	1800 RPM	
Impeller Type	ShinMaywa Vortex Impeller	
Material		
Pump Housing	Cast Iron (ASTM A48 Class 30)	
Impeller	Cast Iron (ASTM A48 Class 30)	
Shaft	420J2 Stainless Steel	
Motor Frame	Cast Iron (ASTM A48 Class 30)	
Fastener	304 Stainless Steel	
Mechanical Seal Materials	Double Mechanical seal	
Upper Side	Silicon Carbide / Silicon Carbide	
Lower Side	Silicon Carbide / Silicon Carbide	
Bearing		
Upper Side	Single Deep Groove Ball Bearing (AC Bearing)	
Lower Side	Single Deep Groove Ball Bearing	
Motor Protection	Thermal Protector	
Accessory	Submersible Cable	32ft(10m) Longer Cable

SPECIFICATIONS (OPERATING CONDITION)

- Applied Water quality

Temperature	0-104 °F, 0-40°C
pH	6 - 9
Electric Conductivity	1,000 μ S/cm or less
DO (Dissolved Oxygen)	1 – 4 mg (O ₂)/ ℓ
Chlorine Iron	1,000 mg/ ℓ or less
SS	3,000 mg/ ℓ or less
BOD, COD	1,000 mg/ ℓ or less
Viscosity	5cP or less
Liquid Specific Gravity	1.05 or less
Sludge Concentration	1% or less

MODEL : 65CVC41.5S-2

BORE	OUT PUT		POLE	RPM	PHASE	VOLTAGE	HZ	RATED AMPERAGE	STARTING METHOD	INS. CLASS	SOLIDS DIA.
	HP	kW									
2.5" (65mm)	2	1.5	4	1800	1	230	60	10.0	Capacitor Run	E	2" (50mm)

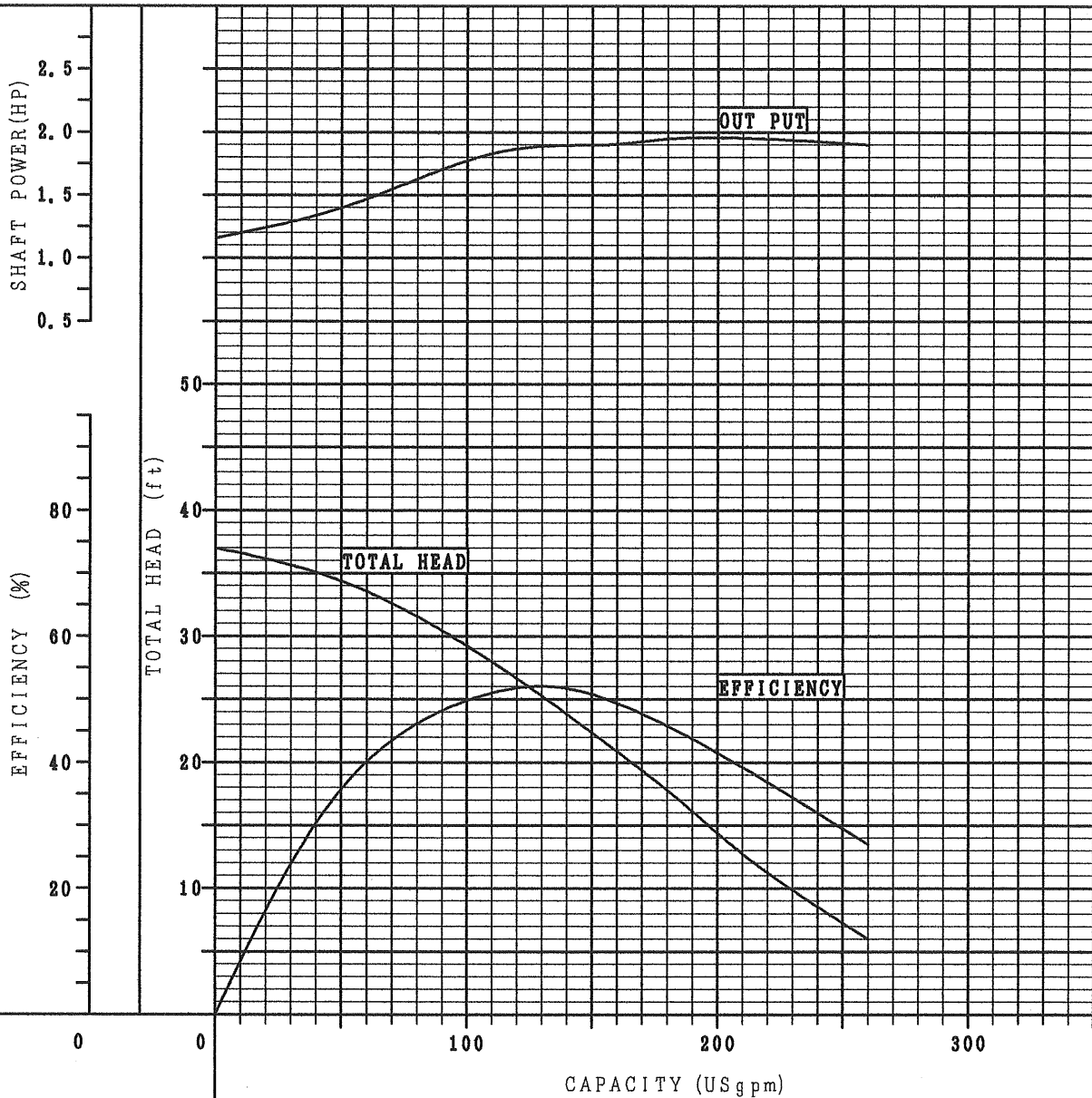

Performance with clear water and ambient temp Max. 32°C

TITLE

PERFORMANCE CURVE

DWG No.

Y400575

S 60Hz

ShinMaywa

STAND ALONE INSTALLATION TYPE PUMP DIMENSION

DIMENSION: inch

MODEL	RATED POWER (HP)	FREQ.
65CVC41.5S-2(-P)	2	60

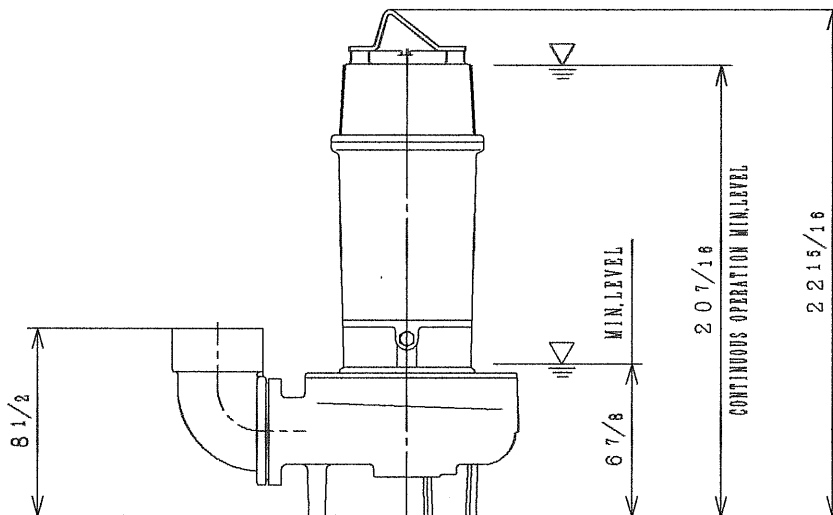
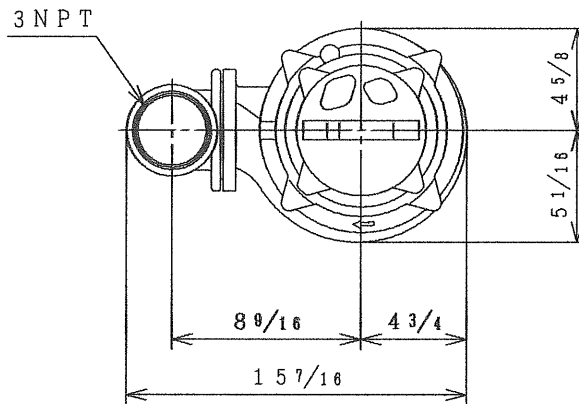

[Note] Limit operation to maximum 30 minutes in the event of operating the pump at the minimum water level.
Secure designated continuous operation minimum water level in the event of continuous operation.

				TITLE	DWG No.
				PUMP DIMENSION	A 4 0 1 7 8 0

K P H

ShinMaywa Industries, Ltd.

MODEL	OUT PUT (HP)
65CVC41, 5S-2	2

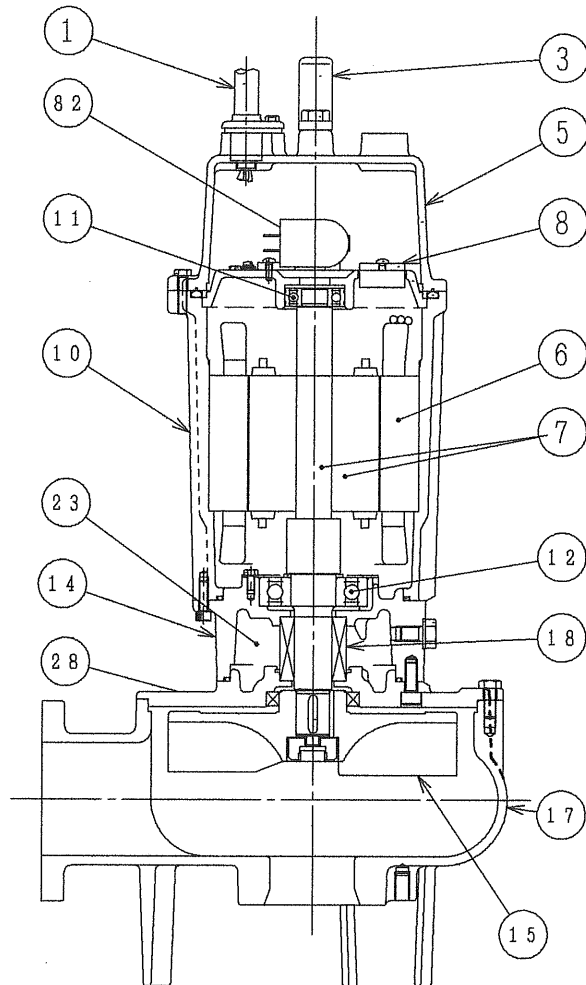

TITLE

PUMP SECTION

DWG No.

A 4 0 1 7 8 5

MATERIALS LIST
65CVC41.5S-2

No.	Denomination	Material
1	Cable(Power)	VCT Polyvinylchloride sheathed cable
3	Handle	SUS304 series (ASTM S304SERIES) Stainless Steel
5	Motor Cover	FC200 (ASTM A48 Class 30) Gray Iron Casting
6	Stator	_____
7	Rotor Assembly	Shaft=SUS420J2 Stainless Steel
8	Thermal Protector	_____
10	Stator Casing	FC200 (ASTM A48 Class 30) Gray Iron Casting
11	Ball Bearing (Upper)	_____
12	Duplex Ball Bearing (Lower)	_____
14	Oil Casing	FC200 (ASTM A48 Class 30) Gray Iron Casting
15	Impeller	FC250 (ASTM A48 Class 35) Gray Iron Casting
17	Pump Casing	FC250 (ASTM A48 Class 35) Gray Iron Casting
18	Mechanical Seal	Upper : SiC/SiC Lower : SiC/SiC
23	Oil	Turbine Oil #32
28	Mechanical Seal Bracket	FC200 (ASTM A48 Class 30) Gray Iron Casting
82	Capacitor	32 μ F 400VAC

				TITLE	DWG No.
				MATERIALS LIST	A401791

65CVC41.5S-2

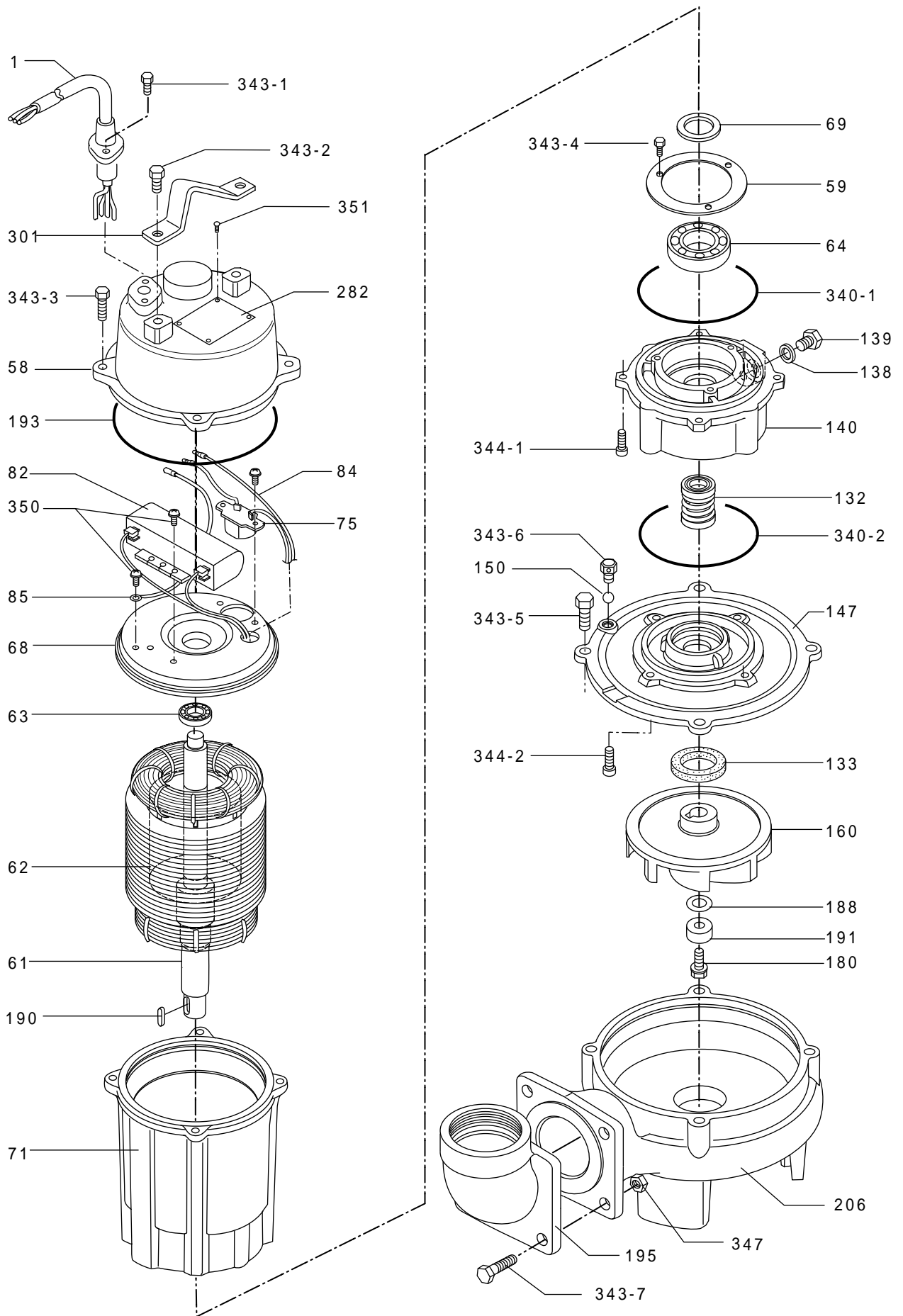

Parts List

No.	Part name	Part No.	Qty					Note	
			65CVC41.5S-2	65CNL41.5T-2	80CNL42.2T-2	80CNL43.7T-2	100CNL45.5T-2		100CNL47.5T-2
1	Power Cable	BK1519-A	1						
		B76666-B		1					
		B82413-E			1				
		B82414-E				1			
		B82415-E					1		
58	Motor Cover	B82416-E						1	
		C78039-D	1						
59	Bearing Holder	C44853-A		1					
		A81577-A	1	1					
		B78732-A			1				
		B78777-A				1			
61	Rotor Assy	B76642-A					1	1	
		C61475-A	1						
		C61463-A		1					
		C44349-A			1				
		C44350-A				1			
62	Stator Assy	D63383-A					1		
		D63383-C						1	
		C61475-B	1						
		C61463-B		1					
		C44349-0			1				
63	Upper Bearing	C61333-A				1			
		D77670-W					1		
		D77670-Z						1	
		S94159-C	1	1					
64	Lower Bearing	S94159-A			1	1			
		S94159-D					1	1	
		S63123-G	1	1					
		S63123-D			1				
68	Bearing Plate	S63123-H				1			
		S63123-F					1	1	
		C44854-D	1						
69	Bearing Washer	A81578-B	1	1					
		C76814-A	1	1					
71	Stator Casing	C83661-A			1				
		C83660-A				1			
		D77897-A					1		
		D77897-B						1	
75	Auto-Cut (Thermal Protector)	SY3387-K	1						
		S63403-H		1					
		AM3862-A			1				
		AM3863-B				1			
		H18347-C					1		
78	Auto-Cut Cover	H18347-D						1	
		B82711-A			1				
82	Capacitor	B82711-B				1	1	1	
		SY5978-A	1						
85	Ground Wire	AV0652-B	1						
		A78004-B	1	1					
		A83430-A			1				
		A83430-B				1			
95	Pipe Spacer	A83430-C					1		
		A83430-D						1	
		S62952-C			2				
		S62952-D				2	2	2	
96	Packing	B78728-A			1				
		B78728-B				1	1	1	
101	Stator Collar	AM2949-A			1				
		AM2949-B				1			
		H15715-A					1	1	
129	Equalizer	A83187-A			1	1	1	1	
132	Mechanical Seal	S64397-A	1	1	1				
		S64398-A				1			
		S64399-A					1	1	
133	Oil Seal	S62962-K	1	1					
		S62962-J			1	1			
		S62962-H					1	1	
138	Check Plug	111S1016	1	1					
		111S1625			2	2	2	2	
139	Gasket	A76838-T	1	1					
		AM7943-D			2	2	2	2	
140	Oil Casing	D63662-A	1	1					
		D63378-A			1				
		D63390-A				1			

Parts List

No.	Part name	Part No.	Qty						Note
			65CVC41.5S-2	65CNL41.5T-2	80CNL42.2T-2	80CNL43.7T-2	100CNL45.5T-2	100CNL47.5T-2	
		D63382-A					1	1	
147	Mecanical Seal Bracket	C60936-A	1						
150	Ball	AP8781-A	1						
		A83188-A			1	1	1	1	